



## Cambridge International AS & A Level

CANDIDATE  
NAME

CENTRE  
NUMBER

--	--	--	--	--	--

CANDIDATE  
NUMBER

--	--	--	--



**PHYSICS**

**9702/51**

Paper 5 Planning, Analysis and Evaluation

**May/June 2023**

**1 hour 15 minutes**

You must answer on the question paper.

No additional materials are needed.

### INSTRUCTIONS

- Answer **all** questions.
- Use a black or dark blue pen. You may use an HB pencil for any diagrams or graphs.
- Write your name, centre number and candidate number in the boxes at the top of the page.
- Write your answer to each question in the space provided.
- Do **not** use an erasable pen or correction fluid.
- Do **not** write on any bar codes.
- You may use a calculator.
- You should show all your working and use appropriate units.

### INFORMATION

- The total mark for this paper is 30.
- The number of marks for each question or part question is shown in brackets [ ].

This document has **8** pages.

## 2

- 1 A wooden cube of mass  $A$  is placed on an inclined plane. The cube is attached to a cylinder of mass  $B$  using string that passes over a pulley, as shown in Fig. 1.1.

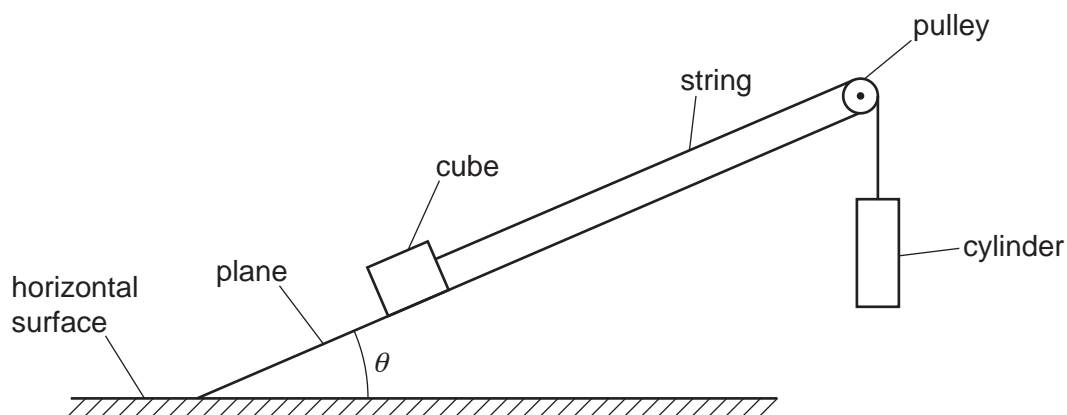

**Fig. 1.1** (not to scale)

The angle between the plane and the horizontal surface is  $\theta$ . Initially the cylinder is held at rest.

The cylinder is released. The time for the cylinder to fall a distance  $d$  is  $t$ .

It is suggested that  $t$  is related to  $\theta$  by the relationship

$$\frac{2d}{t^2} = -\frac{AH \sin \theta}{(A+B)} - \frac{KA}{(A+B)}$$

where  $H$  and  $K$  are constants.

Plan a laboratory experiment to test the relationship between  $t$  and  $\theta$ .

Draw a diagram showing the arrangement of your equipment.

Explain how the results could be used to determine values for  $H$  and  $K$ .

In your plan you should include:

- the procedure to be followed
- the measurements to be taken
- the control of variables
- the analysis of the data
- any safety precautions to be taken.





- 2 A student investigates the discharge of capacitors in the circuit shown in Fig. 2.1.

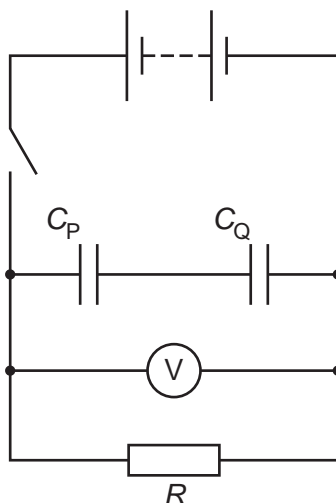

**Fig. 2.1**

The capacitors have capacitances  $C_P$  and  $C_Q$ .

The student closes the switch to charge the capacitors and then records the maximum reading  $V_0$  on the voltmeter.

The switch is opened and a stop-watch is started. The capacitors discharge through the resistor and the reading on the voltmeter decreases. When the reading on the voltmeter is  $V$  the time  $t$  is recorded. The discharge of the capacitors is repeated and the mean time  $T$  is calculated.

The experiment is repeated for different values of  $C_P$  and  $C_Q$ .

For each combination of  $C_P$  and  $C_Q$ , the combined capacitance  $C$  is calculated.

It is suggested that  $C$  and  $T$  are related by the equation

$$\ln\left(\frac{V}{V_0}\right) = -\frac{T}{CR}$$

where  $R$  is the resistance of the resistor.

- (a)** A graph is plotted of  $T$  on the  $y$ -axis against  $C$  on the  $x$ -axis.

Determine an expression for the gradient.

gradient = ..... [1]

(b) Values of  $C_P$ ,  $C_Q$  and  $t$  are given in Table 2.1.

**Table 2.1**

$C_P/10^{-4}\text{F}$	$C_Q/10^{-4}\text{F}$	$C/10^{-4}\text{F}$	$t/\text{s}$	$t/\text{s}$	$T/\text{s}$
2.2	1.5		12.9	14.5	
2.2	3.3		21.1	19.7	
2.2	5.6		23.7	24.9	
3.3	1.5		15.3	16.9	
5.6	1.5		19.0	17.6	
5.6	3.3		30.9	32.1	

The relationship between  $C$ ,  $C_P$  and  $C_Q$  is

$$C = \frac{C_P C_Q}{C_P + C_Q}$$

Calculate and record values of  $C/10^{-4}\text{F}$  and  $T/\text{s}$  in Table 2.1.  
Include the absolute uncertainties in  $T$ .

[2]

(c) (i) Plot a graph of  $T/\text{s}$  against  $C/10^{-4}\text{F}$ .  
Include error bars for  $T$ .

[2]

(ii) Draw the straight line of best fit and a worst acceptable straight line on your graph. Label both lines.

[2]

(iii) Determine the gradient of the line of best fit. Include the absolute uncertainty in your answer.

gradient = ..... [2]

7

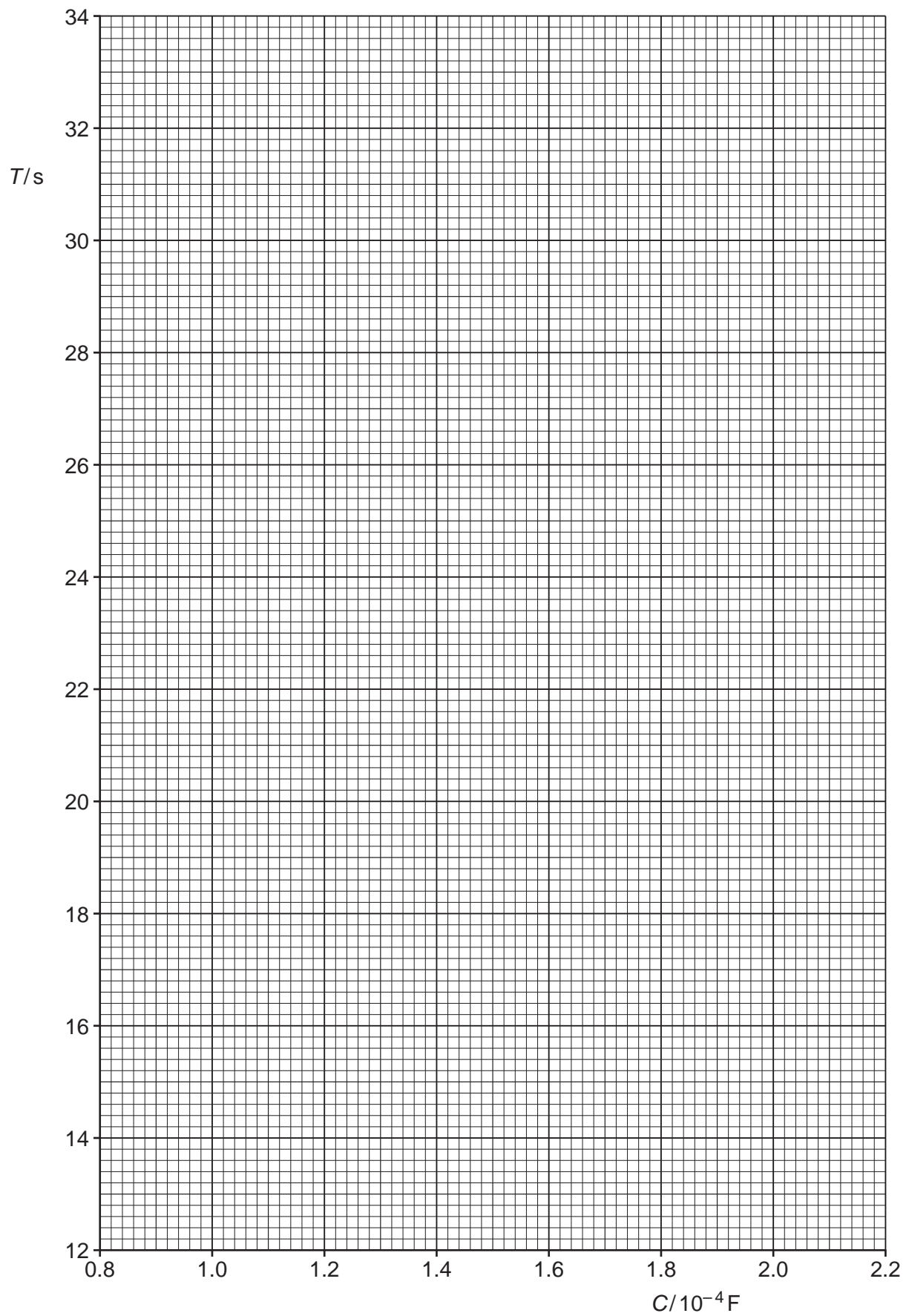

(d) The values of  $V_0$  and  $V$  are:

$$V_0 = (4.8 \pm 0.1) \text{ V}$$

$$V = (2.4 \pm 0.1) \text{ V}$$

Calculate  $\ln\left(\frac{V}{V_0}\right)$ . Include the absolute uncertainty in  $\ln\left(\frac{V}{V_0}\right)$ .

$$\ln\left(\frac{V}{V_0}\right) = \dots\dots\dots [1]$$

(e) (i) Using your answers to (a), (c)(iii) and (d), determine the value of  $R$ . Include an appropriate unit.

$$R = \dots\dots\dots [2]$$

(ii) Determine the percentage uncertainty in  $R$ .

$$\text{percentage uncertainty in } R = \dots\dots\dots \% [1]$$

(f) The experiment is repeated. Determine the value of  $C$  that gives a value of  $T$  of 60.0 s. Include the absolute uncertainty in your answer.

$$C = \dots\dots\dots \text{ F } [2]$$

[Total: 15]